

INSTALLATION, OPERATIONS AND MAINTENANCE FOR SHARPE[®] SERIES 76- 3 WAY BALL VALVE



2701 Busse Road Elk Grove Village, Illinois 60007

Phone: (877) 774-2773

Fax: (708) 562-9250



www.sharpevalves.com



GENERAL

The following instructions only refer to Sharpe[®] standard valves as described in the current catalog. Keep protective covers in place until moment of installation. Valve performance depends upon prevention of damage to the valve. Upon removal of cover, make sure that the valve is completely free of obstructions.

When shipped, valves may contain a lubricant which aids the assembly of the valve; this may be removed if found objectionable.

Safety precautions

Before removing the valve from a pipeline: media flowing through a valve may be under pressure, corrosive, toxic, flammable, or of a contaminant nature. It is recommended that the following safety precautions should be taken when handling valves:

- Always wear eye shields
- Always wear gloves and overalls
- Wear protective footwear
- Wear protective headgear
- Ensure that running water is easily available
- Have a suitable fire extinguisher ready if media is flammable

By checking line gauges, ensure that no pressure exits on either the upstream or the downstream sides of the valve.

Ensure that any media is released by operating valve slowly to each position. Ideally, the valve should be decontaminated when the ball is half open in each flow plan. Leave valve in a fully open position.

Operation

Sharpe[®] valves provide tight shut off when used under normal conditions and in accordance with Sharpe[®] valves published pressure/temperature chart.

It is not recommended that these valves be used in a partially open (throttled) position in any flow plan, seat life will be greatly reduced.

Any media which might solidify, crystallize or polymerize should not be allowed to stand in the ball valve cavities unless regular maintenance is provided.

Manual operation

Series 76- Three-way ball valves allow 0°, 90°, and 180° rotation increments based on the different flow path arrangements listed below. The handle is designed to be able to be locked in every 90° position.

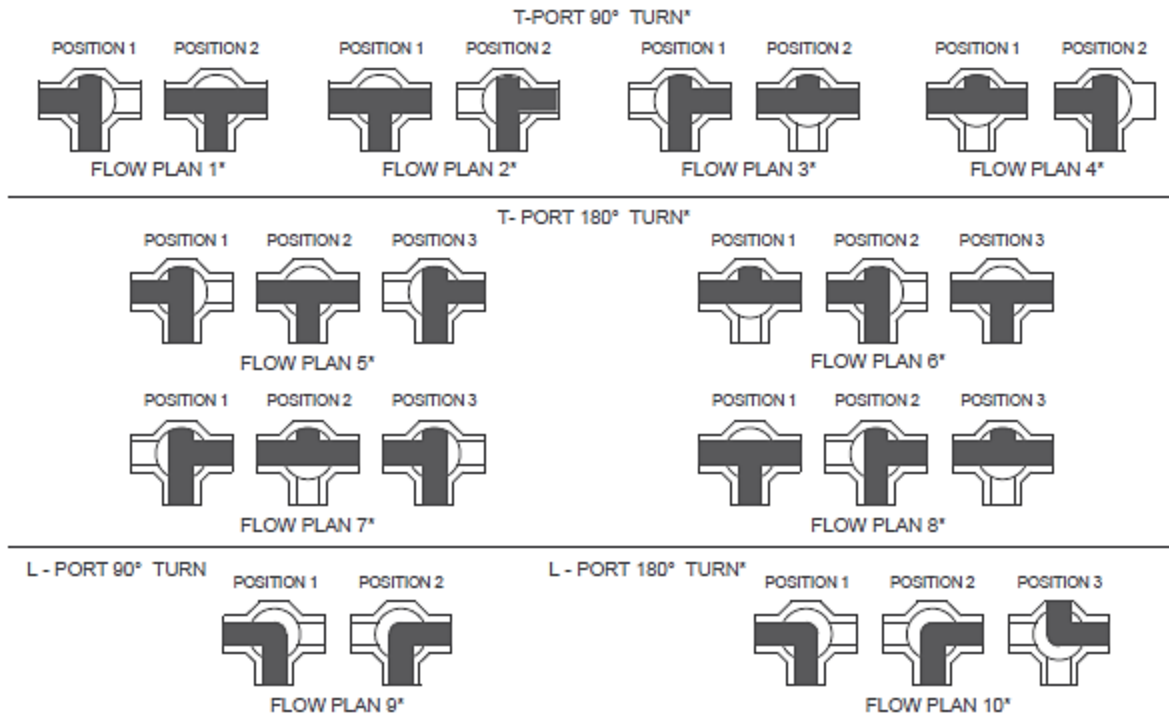

*Not to be used as an isolation valve.

Remote operation

Where manual operation is not required, valves may be automated for remote operation, instrument control, etc. A range of Sharpe[®] valves pneumatic and electric actuators are available.

Operation will be in accordance with Sharpe[®] valves installation, operation and maintenance instructions for the relevant actuator.

Valves with actuators should be checked for alignment of the actuator to the valve. Angular or parallel misalignment may result in high operational torque and potential damage to the stem seals or stem.

MAINTENANCE

Sharpe[®] ball valves have been designed and engineered to provide long lasting and trouble-free service when used in accordance with the instructions and specifications herein.

Before installing the valves, the pipes must be flushed clean of dirt, burrs and welding residues, or you will damage the seats and ball surface.

These valves may be installed in any position using good pipe fitting practices.

General

With self-wipe ball/seats Sharpe[®] valves have a long, trouble-free life, and maintenance is seldom required. When necessary, valves may be refurbished, using a small number of components, none of which require machining.

Sharpe[®] valves are designed for easy service and assembly in the field. The following checks should, however, help to extend valve life or reduce plant problems.

Stem leakage in valves

Examine the Belleville washers for damage. If in good condition, tighten the packing nut until disk springs are firmly compressed, then back nut off 1/16" of a turn. If damaged, dismantle the stem down to the gland, install new Belleville washers with their outer edges touching.

Further maintenance necessitates dismantling of the valve. Note: stem leakage if not cured by the simple means described above, necessitate dismantling the valve. If there is no stem leakage, the stem assembly should not be touched.

In-Line Leakage

Check that the valve is fully in the correct orientation. If it is, leakage will be due to a damaged seat or damaged ball sealing surfaces, and it will be necessary to dismantle the valve.

Note: these valves are not to be used as isolation valves so any leakage through a port that is isolating a flow is not the responsibility of Sharpe[®] valves.

Leakage at Pipeline Joint

Check that the joints are all aligned to the valve and assure the fitting, either threaded or socket welded, is properly assembled according to good pipe fitting practices.

DISASSEMBLY

Note: We only give the standard valve disassembly instructions. For more details, contact Sharpe[®].

Before disassembly of valves from the pipeline cycle the valve with the line pressure fully relieved before attempting to remove the valve from the pipeline to insure pressure has also been discharged from the valve cavity.

1. Remove valve from the line. Care should be taken to avoid scratching or damaging any part of the valve.
2. Hold the valve in a fixture or vise and using the proper socket remove the 3 end pieces [2] with the end seals [7] by turning them in a counter-clockwise direction. Be sure not to apply too much force or you could damage the ends. The seals should come off with the ends but if they don't just manually remove them from the valve body [1] and discard them.
3. Remove and discard the three seats [4] that were behind the 3 ends. Be careful not to damage the sealing surfaces of the end pieces.
4. To take out the ball [3], rotate stem [5] so the tang is aligned with the large port in the body. Carefully pull the ball off stem tang and out of the body [1] with a "rolling" motion. Note: Extreme caution should be taken to avoid damage to the ball. Also, note the position of the ball [3] so that it can be put back in the same way.
5. With the ball out you can now remove the 4th seat [4] from the dead end side of the valve body [1].
6. To dismantle the stem assembly, first remove the handle nut [13] and handle [15] from the stem [5]. Using a wrench to prevent the stem from turning, bend down the lock tab fingers and then remove second handle nut [13], lock tab [12], Belleville washers [11] and gland [10]. It is normally not possible to remove stem packing at this stage. Note the position of the handle so that it can be put back on the same way.
7. Withdraw the stem [5] through the body cavity and remove the thrust washer [6] from the stem.
8. Remove the thrust washer [9] and stem packing [8] through the top of the stem bore.
9. Clean all components thoroughly and examine all seating/sealing surfaces in the body [1] and end caps [3] as well as the surface of the ball and stem packing area of the stem [5].
10. If there is build-up of solids which cleaning fluids will not remove you will need to get them off manually ensuring that you do not scratch any of the surfaces.
 - Note: No eroded or corroded leak paths are permissible. If any are found, the valve must be replaced as we do not stock individual metal components for this valve series. The ball must have no scratches across its seating surfaces and any damage to the port lip will destroy the new seats – a damaged ball must result in valve replacement also.

REBUILDING

Before rebuilding, check that all the correct components are available and that they are fit for re-assembling. Only official Sharpe[®] repair parts should be used. When rebuilding, cleanliness is essential to allow long valve life and provide cost effective maintenance.

1. With the valve body [1] securely held in a fixture or vise install one seat [4] into the dead end side of the valve body [1]. The side with the spherical curvature face should be facing out towards the ball cavity.
2. Slide the thrust washer [6] onto the stem and insert the stem [5] into the body [1] and then push it all the way up into the stem hole
3. While still holding the stem [5] up in the stem hole slide the stem packing [8] down onto the stem [5] from the top followed by the thrust washer [9], then the gland [10], Belleville washers [11], lock tab [12], and lastly tighten the handle nut [13] onto the stem finger tight. Note that for the Belleville washers [11] the first spring goes concave side up and the second spring concave side down.
4. Using a wrench to hold the top of the exposed thread on the stem [5] to prevent it from turning, tighten the nut [13] to the torque value in table 1. Rotate the stem several times to make sure it has a smooth operation.
5. Bend up the fingers on the lock tab [12] so either both come up a flat side of the nut [13] or straddle a corner. You may need to tighten slightly more to allow this alignment. Keep in mind excessive over tightening will only reduce the life of the stem assembly.
6. Next fit the handle [15] to the stem [5] in same orientation as it was removed and tighten down the handle nut [13] on to the stem [5].
7. Rotate the stem [5] so the stem tang is aligned with the large port in the body [1] and gently slide the ball [3] on the tang in the same orientation as it came out. Note: extreme caution should be taken to avoid damage to the ball.
8. Gently insert the seats [4] into the other 3 ports. Making sure the spherical curvature face is facing in towards the ball cavity.
9. Assemble the body seals [7] on to the 3 end caps [2].
10. Place a small amount of anti-seize lubricant on the threads to prevent galling and gently thread the end caps [2] back into the body and tighten them to the torque listed in table 1. Be sure not to apply too much force or you could damage the ends.
11. Cycle the valve open and closed several times slowly to ensure that the operation is smooth and free of binding or sticking.

INSTALLATION OF THREADED END VALVES

1. Use conventional sealant, such as TFE tape, etc. on the threads.
2. Apply correct size wrench on the end cap of the ball valve only. Tightening by using the valve body or handle can severely damage the valve.
3. Always use 2 wrenches one to hold the end cap from rotating and the other to rotate the pipe.
4. Valves should always be assembled using good pipe fitting practices and according to local code requirements.

INSTALLATION OF WELD END VALVES

1. Caps must be disassembled and removed from the valve body to prevent heat damage of the soft plastic seats and seals in the valve during welding.
2. Place the valve to the vise and use a socket to unscrew the ends caps. Be sure not to apply too much force or you could damage the ends. Valve must be partially in the open position to prevent the ball from sliding out
3. Place the center section in a clean area where it will not be damaged.
4. Insert the pipe to be welded to the socket of the end cap and tack weld around first and then complete the welding. Once the pipes are fully welded to the end caps, and the welds are cool to touch, re-install the seats and seals then re-install welded end caps back to the body. Tighten all the threaded joints of the valve. Note: excessive heat from the welding process can damage the end cap.
5. Valves should always be assembled in line using good pipe fitting practices and according to local code requirements.

Note: For installation of threaded & welded end multi-port ball valves, unions may be installed before each end for easy installation and removal of the valve.

TIGHTENING TORQUE TABLE

Table 1

Series 76 assembly torques		
Size (in)	Stem Nut Torque (in-lbs)	End Cap Torque (in-lbs)
1/4	104	17
3/8	104	17
1/2	104	17
3/4	104	17
1	174	35
1 1/4	174	43
1 1/2	391	52
2	391	61

PARTS BREAKDOWN

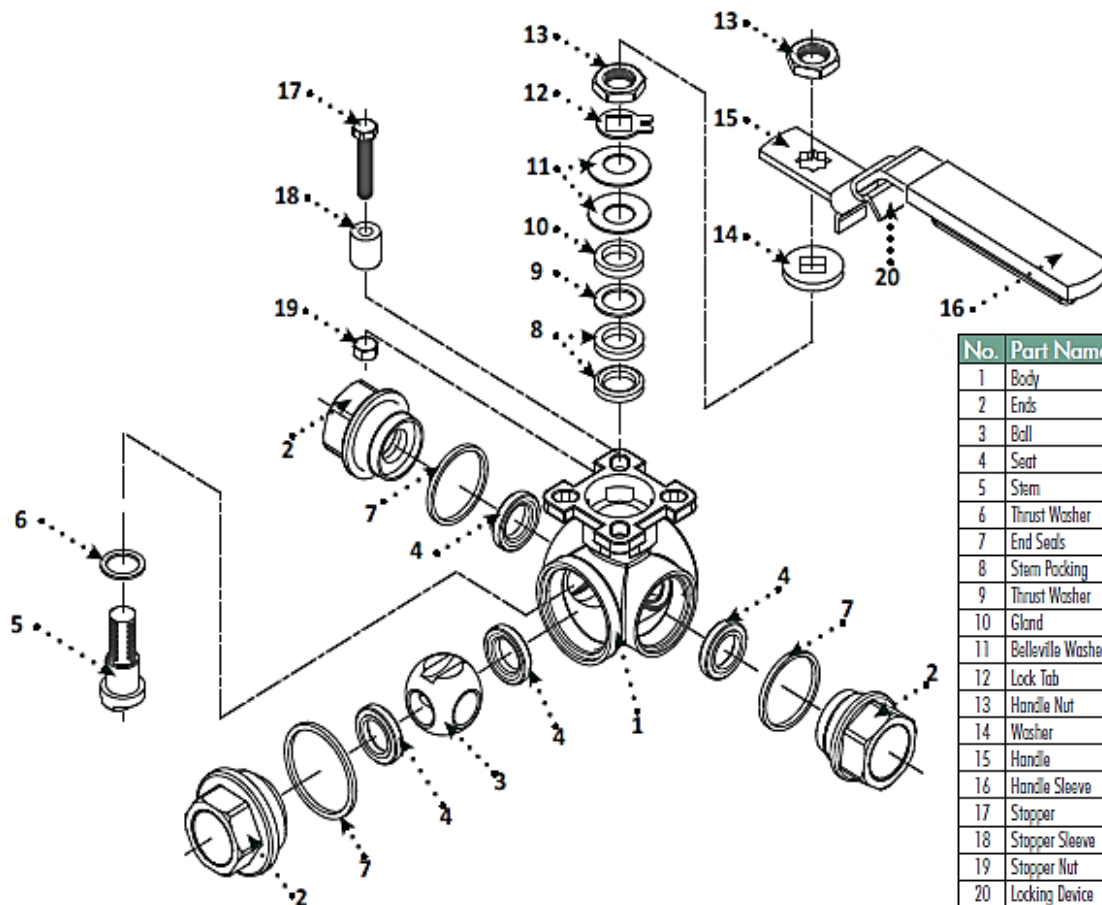

No.	Part Name	Qty	Material
1	Body	1	316 Stainless Steel ASTM A351 CF8M
2	Ends	3	316 Stainless Steel ASTM A351 CF8M
3	Ball	1	316 Stainless Steel
4	Seat	4	TFM®
5	Stem	1	316 Stainless Steel
6	Thrust Washer	1	PTFE
7	End Seals	3	PTFE
8	Stem Packing	2	PTFE
9	Thrust Washer	1	TFM®
10	Gland	1	300 Series Stainless Steel
11	Belleville Washer	2	300 Series Stainless Steel
12	Lock Tab	1	300 Series Stainless Steel
13	Handle Nut	2	300 Series Stainless Steel
14	Washer	1	300 Series Stainless Steel
15	Handle	1	300 Series Stainless Steel
16	Handle Sleeve	1	Vinyl Grip
17	Stopper	1	300 Series Stainless Steel
18	Stopper Sleeve	1	300 Series Stainless Steel
19	Stopper Nut	1	300 Series Stainless Steel
20	Locking Device	1	300 Series Stainless Steel