

SONIC TORQUE®



4X4

4 PISTON PNEUMATIC ACTUATOR

THERE ARE BIG ADVANTAGES TO THINKING SMALL

WHY SMALLER IS BETTER

The Sonic Torque Pneumatic Actuator Series 4x4 packs more than double the torque of conventional rack and pinion actuators. That is because it has four pistons generating torque around a centrally located pinion. With more pistons in the actuator, it allows their diameter to be smaller while generating higher torque. At the same time, it means the size of the actuator can be more compact.



WHY SMALLER IS FASTER

With four small cylinders each located on one of four sides of the unit and at a given air pressure, the 4x4 produces the same torque output as double piston models using smaller diameter pistons and a narrower pinion. Thanks to the narrower pinion, the pistons travel shorter distances so that they can move faster from one position to the next.

WHY SMALLER REDUCES AIR CONSUMPTION

The cube shape coupled with pistons traveling shorter distances minimizes size requirements while maximizing torque output. At the same time, shorter piston travel and compact size greatly reduces pressure requirements compared to other designs and results in reduced energy expenditures.



WHY SMALLER MEANS LESS STRESS

It's a matter of balance. Unlike other designs that produce an off-axis thrust, the 4x4 design positions each piston around the cube so they develop thrust along their own axis. As a result, stressful piston side loading is minimized putting less stress on seals resulting in less wear.



WHY SMALLER IS A BETTER SOLUTION

Because of the four-cylinder design, the 4x4 has many more spring combination possibilities than double piston actuators. This means better solutions under any air pressure requirement. Each chamber can use up to three different spring sizes which nest between the covers and pistons and align by centering rings. Also, springs are wound in opposite directions to avoid tangles during operation.

WHY SMALLER IS STRONGER.

For superior corrosion resistance, the body and covers are anodized internally and externally. Plus, they have an external epoxy base layer and a second polyurethane paint to further reduce corrosion in demanding applications. Extended spray wash downs do not create corrosion problems for the actuator.

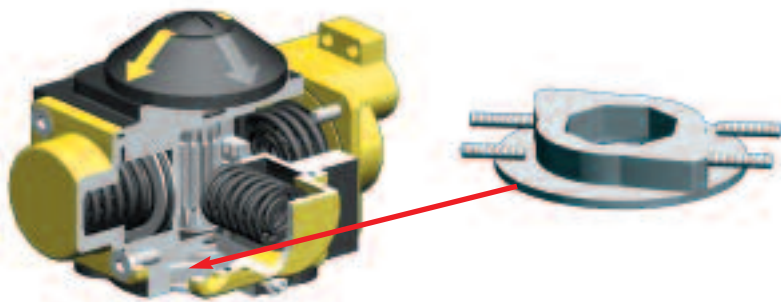

Travel stops can be adjusted by four studs at the base of the actuator. The studs are opposed from each other so no unequal forces are generated, the stop design allows for $\pm 5^\circ$ adjustment in both opening and closing rotations. Mid-stroke stop points can be achieved with longer studs.

Blowout proof and Acetal support pad in body maintains proper contact of the piston racks to the pinion at all times.

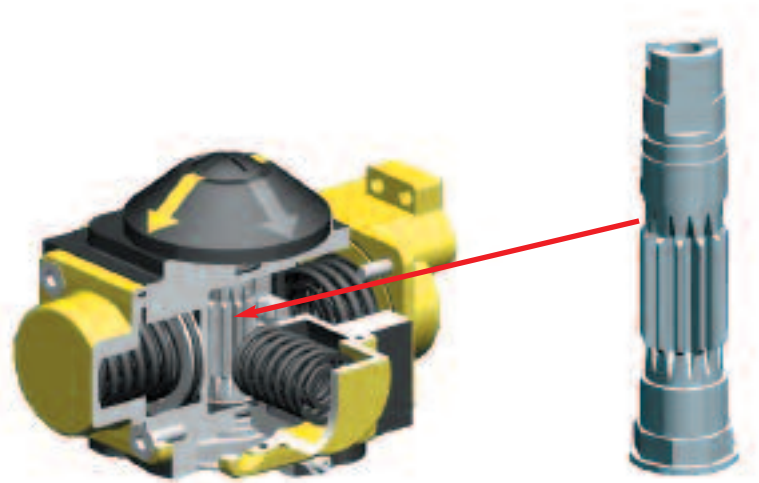

Nested springs are aligned by rings cut in the piston face and end cap. This ensures correct orientation. With four cylinder areas, many different combinations are available allowing for correct sizing.

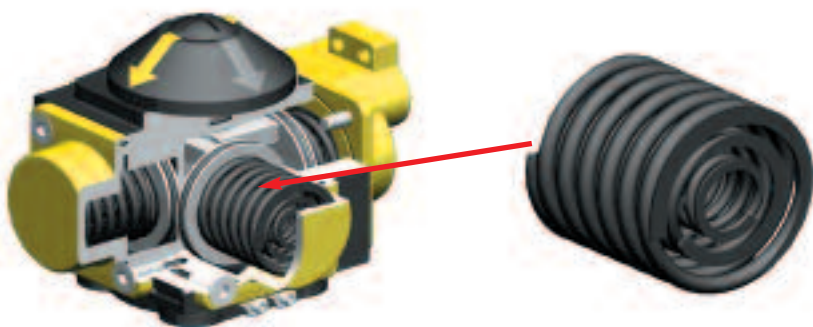

GENERAL FEATURES

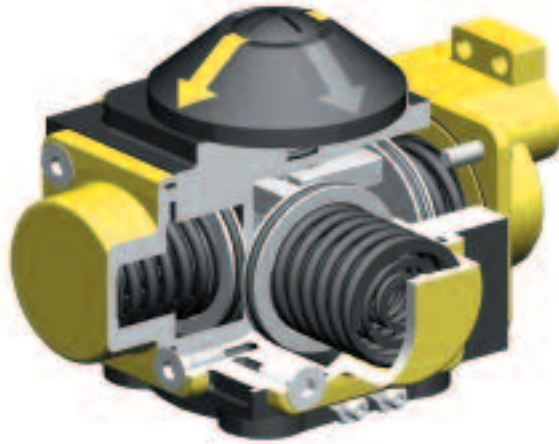

- * SonicTorque® 4 x4 utilizes carbon steel pistons that allow for higher cycles because of their greater strength.
- * Viton seals in the piston drive shaft also lead to higher cycles. Inside surface finish (Ra 0.4-0.6 um) to minimize friction and to maximize the life of the actuator.
- * Standard applications for temperature ranges from
 - BUNA -4°F to 176°F
-20°C to 80°CAlso Available:
 - Viton -4°F to 250°F
-20°C to 120°C
 - EPDM -40°F to 176°F
-40°C to 80°C
- * Piston bearing made of material with low friction coefficient to avoid metal to metal contact. Easily replaceable for maintenance.
- * Double lower drilling for valve mounting, and centering, according to ISO 5211/DIN 3337 standards.
- * Independent bi-directional travel stop adjustment +/- 5° ensuring precise positioning in all flow control services, adjustable between 85°-95° rotation.
- * Direct mounted solenoid connections according to NAMUR standards. Lower female shaft key, according to ISO 5211/DIN 3337 standards, for assembly on valves with star or square shaft.
- * Air supply: can be dry or lubricated filtered compressed air.
- * The lubrication carried out by the manufacturer qualifies for a minimum of 1,000,000 operations.
- * Epoxy-coating is a deposit of powders on clean and sandblasted pieces. The chemical process is easily kept under control and after coating, the pieces must be subjected to heat treatment. Epoxy painting of actuators is advised where environment is strongly aggressive. With a normal thickness of 200/250 microns, resistance to salty fog exceeds 1,000 hours. With the exception of certain solvents, epoxy coating resists acids and alkali, and also has a good resistance to UV rays. In order to retain its properties, the coating must not be scratched.
- * Visual position indicator the 4 x 4 actuators are supplied as standard.
- * The indicator designed to remain on the actuator for continuous indication when limit switch is being used.**

** (Not applicable in size X40)

PARTS AND IDENTIFICATION

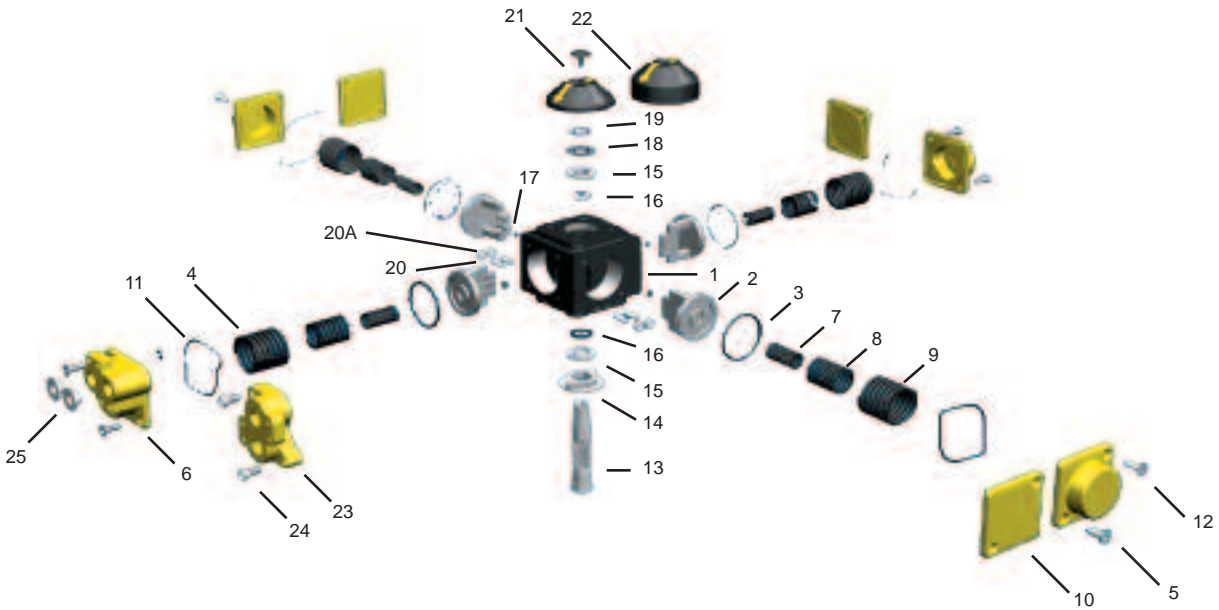

PART NO.	QTY	PART DESCRIPTION	STANDARD MATERIAL
1	1	BODY	Aluminum AL101A-T6
2	4	PISTON	Carbon Steel S45C Nickel Plated
3	4	PISTON "O" RING	BUNA / Viton / EPDM
4	4	COVER "O" RING	BUNA / Viton / EPDM
5	3	SPRING RETURN COVER	Aluminum AL101A/101
6	1	NAMUR COVER	Aluminum AL101A/101
7	Max 4	INNER SPRING	Painted Spring Steel
8	Max 4	MIDDLE SPRING	Painted Spring Steel
9	Max 4	OUTER SPRING	Painted Spring Steel
10	3	DOUBLE ACTING COVER	Aluminum AL101A/101
11	1	AIR SUPPLY "O" RING	BUNA / Viton / EPDM
12	8	COVER SCREW	Stainless Steel 304
13	1	PINION	Steel
14	1	STROKE ADJUSTMENT STOP	Stainless Steel 304
15	2	THRUST WASHER	Acetal / NOVA
16	2	PINION "O" RING	Viton / EPDM
17	4	PAD	Acetal
18	1	DISC BEARING	Stainless Steel 304
19	1	SNAP RING	High Alloy Spring Steel
20	4	STROKE ADJUSTMENT STUD	Stainless Steel 304
20A	4	NUT	Stainless Steel 304
21	1	INDICATOR	ABS
22	1	INDICATOR BOLT	ABS
23	1	NAMUR INSERT (SIZES 90/ 115)	AL101A/101
24	2	BOLT (SIZES 90/ 115)	Stainless Steel 304
25	2	PLUG	Plastic

OPERATIONS

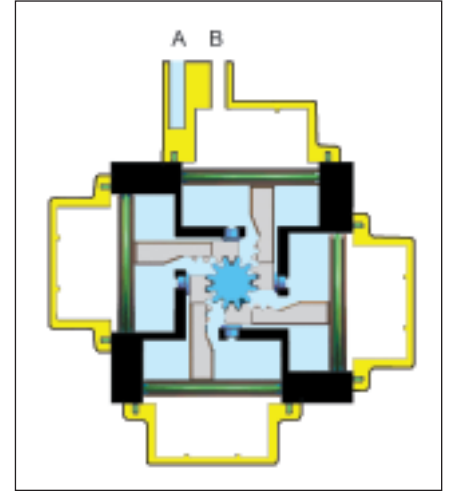
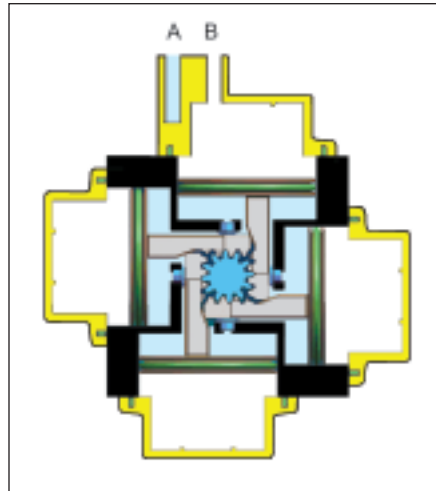
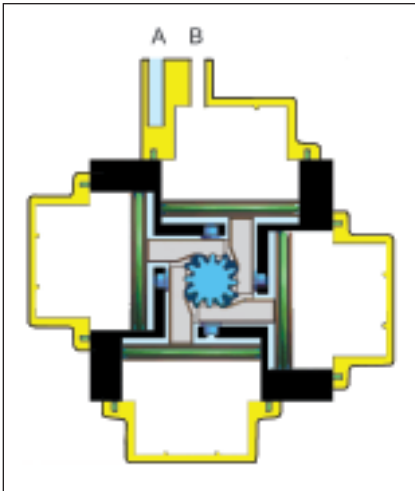

Air supplied to Port A which is connected to the center chambers forces piston apart toward end position with exhaust air exiting at Port B (a counterclockwise rotation is obtained).

Air supplied to Port B which is connected to the four chambers forces piston toward center with exhaust air exiting at Port A (a clockwise rotation is obtained).

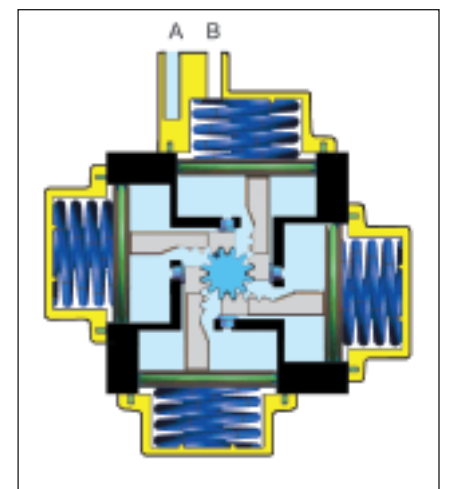
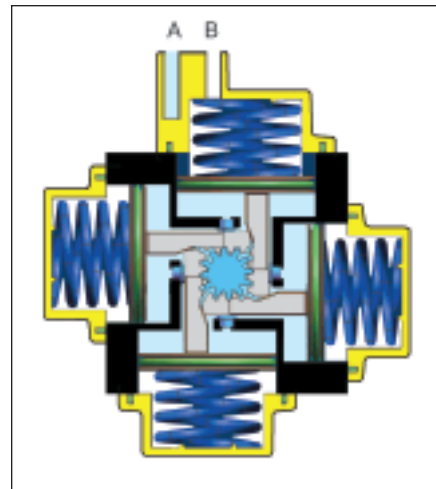
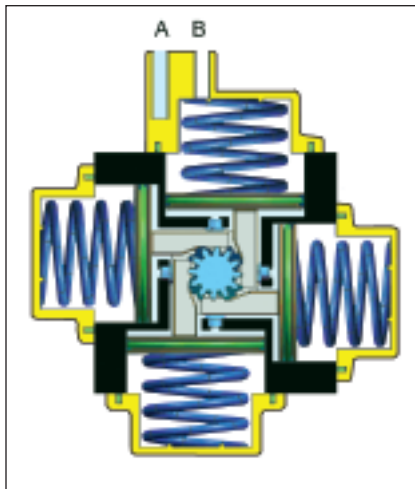

Air supplied to Port A which is connected to the center chamber forces piston apart and toward end position compressing springs, with exhaust air exiting at Port B (a counterclockwise rotation is obtained).

Release of air allows springs to force pistons toward center position with exhaust air exiting at Port A (a clockwise rotation is obtained).

ACTUATION SIZING GUIDE

The seat material used, media, temperature, frequency of operation and critical application of the valve's operation are all important factors in calculating the actuation needs of a given valve. The information provided below should be considered as a guide only and must be adjusted according to experience and judgement. Proper actuator selection is required to prevent valve or process equipment damage as well as proper valve operation.

For determining torque we assume that valve torque results from the friction between the ball and seats as well as the stem and stem seals.

Valve Torque

The torque requirements of Sharpe® Ball Valves will vary depending on several factors.

- **Seat design and material**
The seat friction force depends on the seat material and the applicable service factor multipliers shown in the chart below.
- **Stem Seal**
Torque results from the stem contact with stem seals and the type of packing materials affect torque. Stem seal torque needs to be considered as a percentage of overall torque especially in small valve sizes.

Service Conditions To Consider

- **Differential Pressure** Minimum and maximum pressures
- **Frequency of Operation** Stuck valve torque
- **Media Influence** Slurries, dry gases, oils
- **Temperatures** Minimum and maximums
- **Cycle Time** Line hammer, process requirements
- **Instrument Air Supply** Peak demand pressure availability

Media and Service Factors

To establish minimum torque requirements, multiply valve torque by the following application media and service factors.

Media Factors	Multiplier	Service Factor	Multiplier
Clean particle free, non-lubricating (water, alcohol or solvents)	1.00	Simple On and Off Operations	1.00
Clean particle free, lubricating oil	0.80	Throttling	1.20
Slurries or heavily corroded and contaminated systems	1.30 to 2.00	Positioner Control	1.50
Gas or saturated steam, clean and wet	1.00	Once per day session	1.20
Gas or superheated steam, clean and dry	1.30	Once every two days or more or plant critical	1.50
Gas, dirty unfiltered e.g. natural gas, chlorine	1.20 to 1.50		

Double Acting Actuator (DA)

In the double acting actuators, the control pinion rotation and its reversal are obtained by reversing the supply to the two input ports. The output torques obtainable mainly depend on the cylinder diameter and the supply pressure; by increasing one or both factors, the available torque also increases. As shown in diagram A, the torque of a DA actuator is constant throughout the entire rotation and relevant reversal. The normal advised safety factor, in addition to the stated valve manufacturer torque, is 20%.

*Select the actuator size whose torque output at given pressure exceeds the valve torque and application factor.

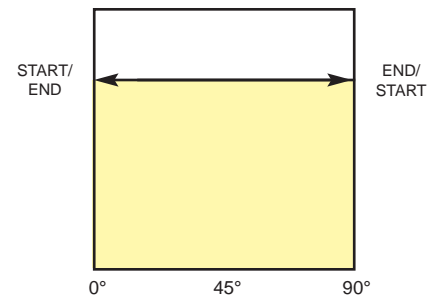

Diag. A

Spring Return Actuator (SR)

In these type of actuators, which utilize springs for reversing the rotation of the control pinion, the output torque depends not only on the cylinder diameter and the supply pressure, but also on the presence of the springs, which should be compressed to guarantee the return. As shown in diagram B, the available torque at 0° progressively reduces during the rotation due to the springs' compression. On the contrary, as shown in diagram C, the torque starting from the 90° position constantly decreases until 0° because of spring extension. Owing to the higher friction present, the safety coefficient in this case is advised 25%.

*Select the actuator whose torque output at 0° and 90° at a given air pressure exceeds the valve torque.

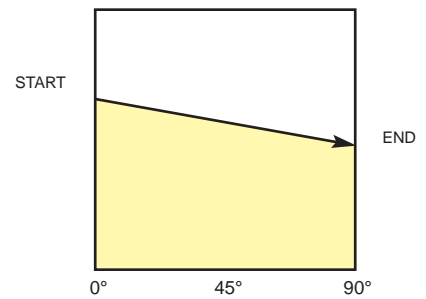

Diag. B

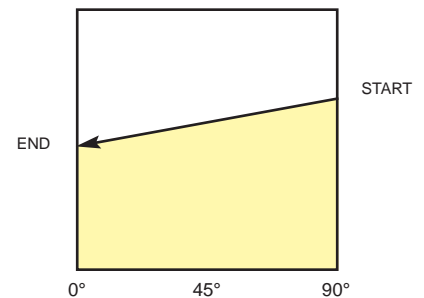

Diag. C

Ball Valve

Ball valve construction concept is based essentially on a polished ball (including a through port) contained in two seats (upstream and downstream). The ball rotation allows the flow, or stops the flow through the valve. Differential pressure between upstream and downstream pressure forces the ball against the downstream seat (floating ball). In this case, the valve torque is generated by the friction between ball and seat and also between stem and packing. As shown in the diagram to the right, the highest torque point is when, in presence of pressure, the valve is in the closed position, and passes to the open position (breakaway torque).

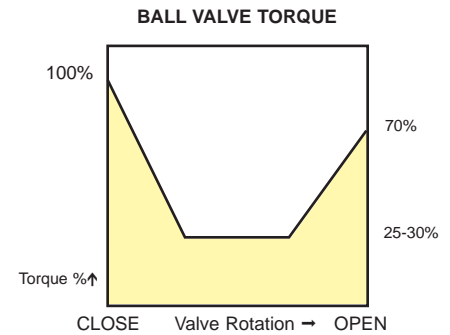

Butterfly Valve

Butterfly valve construction concept is based essentially on a disc fixed on an axis, which in the closed position, is completely contained by the seat. The open position is obtained when, with a rotation, the disc (through its stem) becomes parallel to the flow. On the contrary, the closed position is obtained when the disc is perpendicular to the flow. In the case of the butterfly valve, the torque is generated by the friction between the disc and the seat, by the stem packing and also by the differential pressure that forces on the disc. The highest torque point, as shown in the diagram, is in the closed position, and only after a small rotation it is considerably reduced.

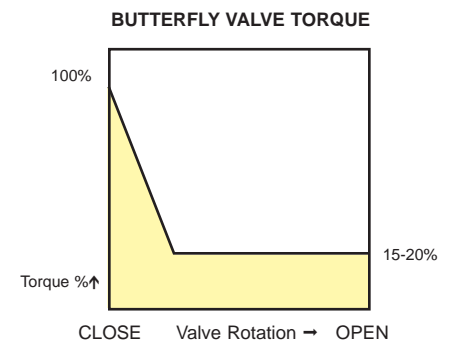

Plug Valve

Plug valve construction concept is based essentially on a male (plug) contained in a female cone (seat). The plug provides a through port in one direction and with its rotation into the seat the opening and closure of the valve is obtained. The torque is usually not influenced by the flow pressure, but is generated essentially by the friction between the seat and the plug, during the opening closing cycle. As shown in the diagram to the right, the highest torque point is in the closed position and remains high for the rest of the operation, because the torque is not influenced by pressure.

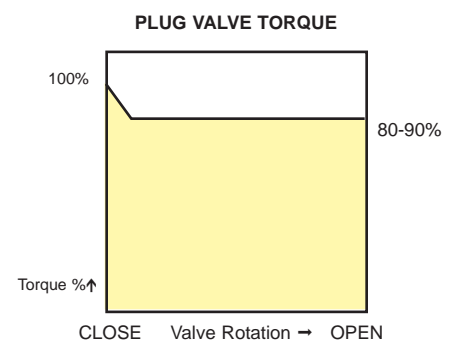

TORQUE RATING

Imperial Unit
in-lb

DOUBLE ACTING							
Air Supply Pressure In PSI	40	60	70	80	90	100	120
Actuator Model							
X40	79	119	137	178	192	218	238
X50	138	230	265	302	339	375	458
X60	315	470	550	657	725	799	959
X75	537	824	948	1074	1208	1340	1648
X90	920	1400	1666	2060	2130	2354	2893
X115	1953	2838	3322	3817	4302	4620	5401

Size	Air Supply Pressure in PSI	SPRING RETURN														Spring Stroke	
		40		60		70		80		90		100		120		Start	End
		Spring Code	Start	End	Start	End	Start	End	Start	End	Start	End	Start	End			
X40	01	52	29	90	64	116	92	136	112	155	130	170	146	215	188	52	30
	02			73	39	100	68	120	87	138	104	154	121	196	159	78	46
	03					84	44	103	62	120	78	137	97	178	131	104	64
	04									104	52	122	72	159	105	130	82
X50	03	82	40	156	108	206	160	244	194	275	224	316	267	389	335	110	67
	04			140	86	193	139	230	173	260	200	303	246	376	313	132	81
	05			122	60	176	114	215	148	242	174	286	220	358	288	158	98
	06					160	89	195	122	226	150	269	196	340	262	185	116
	07					146	79	182	113	211	139	255	186	325	250	196	131
	08							170	89	199	114	243	163	313	226	219	144
	09									188	101	231	149	300	213	234	156
X60	03	204	119	347	249	439	343	519	417	590	485	672	570	818	723	205	118
	04			325	210	419	308	496	379	568	447	651	534	796	684	245	141
	05			305	177	400	275	476	346	547	413	632	502	777	650	279	161
	06					373	237	450	306	520	372	606	462	749	609	320	188
	07					350	193	425	260	495	325	583	418	724	561	368	214
	08							400	219	470	284	559	379	699	519	409	238
	09									452	231	542	229	683	466	461	256
X75	03	235	212	563	432	729	600	859	722	976	834	1126	986	1382	1255	305	189
	04	290	153	520	367	688	538	817	658	933	769	1085	924	1339	1189	370	232
	05			475	270	646	448	772	563	888	673	1042	832	1294	1091	466	277
	06			436	164	603	372	728	486	843	595	999	758	1249	1012	546	323
	07					569	313	693	424	807	531	966	697	1214	948	610	358
	08					552	216	657	348	772	454	931	624	1178	869	686	393
	09									725	368	888	542	1132	781	774	440
X90	03	656	405	1071	780	1346	1061	1559	1260	1748	1439	1995	1692	2428	2146	544	283
	04			1014	678	1291	965	1502	1159	1690	1337	1940	1594	2371	2042	648	340
	05			915	562	1198	855	1405	1045	1592	1221	1845	1484	2273	1925	963	439
	06					1122	703	1326	888	1511	1061	1769	1332	2192	1762	924	519
	07					1061	575	1263	754	1447	926	1708	1203	2129	1625	1065	582
	08							1193	613	1376	782	1640	1065	2059	1478	1206	653
	09									1298	579	1567	968	1980	1375	1309	730
X115	03	1196	645	2019	1437	2542	1975	2968	2370	3347	2732	3820	3218	4652	4087	1167	643
	04			1890	1206	2419	1756	2841	2143	3218	2500	3697	2997	4524	3852	1400	772
	05			1791	1027	2325	1586	2743	1967	3118	2322	3602	2827	4424	3670	1582	870
	06					2174	1318	2585	1687	2959	2038	3450	2558	4264	3382	1866	1030
	07					2051	1097	2458	1458	2828	1805	3325	2336	4136	3147	2100	1160
	08							2330	1230	2699	1574	3203	2115	4007	2910	2335	1289
	09									2573	1341	3083	1894	3881	2675	2568	1414
10									2444	1110	2960	1673	3754	2440	2800	1543	

SPRING ARRANGEMENT

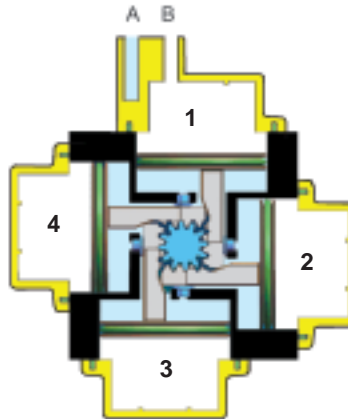

SPRING SETS CODES	SPRING POSITION	CHAMBER 1	CHAMBER 2	CHAMBER 3	CHAMBER 4
1	Inner Spring	√	√	√	√
	Middle Spring	-	-	-	-
	Outer Spring	-	-	-	-
2	Inner Spring	-	-	-	-
	Middle Spring	√	√	√	√
	Outer Spring	-	-	-	-
3	Inner Spring	√	-	√	-
	Middle Spring	√	√	√	√
	Outer Spring	-	-	-	-
4	Inner Spring	√	√	√	√
	Middle Spring	√	√	√	√
	Outer Spring	-	-	-	-
5	Inner Spring	√	√	√	√
	Middle Spring	-	√	-	√
	Outer Spring	√	-	√	-
6	Inner Spring	√	√	√	√
	Middle Spring	-	-	-	-
	Outer Spring	√	√	√	√
7	Inner Spring	√	√	√	√
	Middle Spring	√	√	√	√
	Outer Spring	√	-	√	-
8	Inner Spring	-	-	-	-
	Middle Spring	√	√	√	√
	Outer Spring	√	√	√	√
9	Inner Spring	√	-	√	-
	Middle Spring	√	√	√	√
	Outer Spring	√	√	√	√
10	Inner Spring	√	√	√	√
	Middle Spring	√	√	√	√
	Outer Spring	√	√	√	√

TECHNICAL DATA

	SIZE	X40	X50	X60	X75	X90	X115
Weight of Double Acting	Lb	2.38	3.86	6.81	10.69	16.42	28.66
	Kg	1.08	1.75	3.09	4.85	7.45	13.00
Weight of Double Acting with SR Cover (DS)	Lb	2.42	3.96	6.97	11.16	17.17	29.78
	Kg	1.10	1.80	3.16	5.06	7.79	13.51
Code of Spring Return	Weight of Spring Return Actuator						
01	Lb	2.51	x	x	x	x	x
	Kg	1.14	x	x	x	x	x
02	Lb	2.60	x	x	x	x	x
	Kg	1.18	x	x	x	x	x
03	Lb	2.67	4.17	7.50	12.19	18.92	33.27
	Kg	1.21	1.89	3.40	5.52	8.58	15.09
04	Lb	2.73	4.21	7.58	12.35	19.22	33.91
	Kg	1.24	1.91	3.44	5.60	8.72	15.38
05	Lb	x	4.30	7.76	12.63	19.69	34.55
	Kg	x	1.95	3.52	5.73	8.93	15.67
06	Lb	x	4.39	7.94	12.92	20.15	35.19
	Kg	x	1.99	3.60	5.86	9.14	15.96
07	Lb	x	4.43	7.98	13.07	20.39	35.98
	Kg	x	2.01	3.62	5.93	9.25	16.32
08	Lb	x	4.52	8.20	13.47	20.92	36.77
	Kg	x	2.05	3.72	6.11	9.49	16.68
09	Lb	x	4.56	8.29	13.62	21.25	37.41
	Kg	x	2.07	3.76	6.18	9.64	16.97
10	Lb	x	4.63	8.38	13.78	21.56	38.03
	Kg	x	2.10	3.80	6.25	9.78	17.25

Air Consumption per stroke **	CCW	0.08	0.15	0.29	0.47	0.80	1.3
	CW	0.11	0.19	0.38	0.64	0.95	1.3
Actual Volume - Litre	Total	0.19	0.34	0.67	1.11	1.75	2.6
Air Consumption per stroke **	CCW	4.9	9.2	16.2	28.7	46.3	79.3
	CW	6.7	11.6	21.3	35.1	52.3	82.6
Actual Volume - in ³	Total	11.6	20.7	37.5	63.8	98.6	161.9
Opening Time DA*	Sec.	0.15	0.21	0.39	0.53	1.10	1.60
Closing Time DA*	Sec.	0.16	0.24	0.41	0.54	1.30	1.80

* The above indicated moving time of the actuator, are obtained in the following testcons: (1) Room Temperature. (2) Actuator Stroke 90° (3) Solenoid Valve with orifice of 4mm and flow capacity Qn 400/L/min. (4) Inside pipe diameter 8mm, (5) Medium clean air, (6) Air supply pressure 5.5 bar (79, 75psi), (7) Actuator without external resistance load. Cautions: on the field applications when one or more of the above parameters are different, the moving time will be different.

** "If you plan to use the actuator with the spring return cover as double acting actuator; please consult your representative for the air consumption figures"

Accessory Top Mount NAMUR Standard VDI/VDE 3845
Bottom Mount ISO 5211

OPERATING TEMPERATURE

BUNA	-4°F to 176°F	-20°C to 80°C
Viton	-4°F to 250°F	-20°C to 120°C
EPDM	-40°F to 176°F	-40°C to 80°C

PRESSURE RANGE

DA	20-120 PSI,	1.5 - 8 Bar
SR	30-120 PSI,	2.0 - 8 Bar

SPRING RETURN

X40 - X90

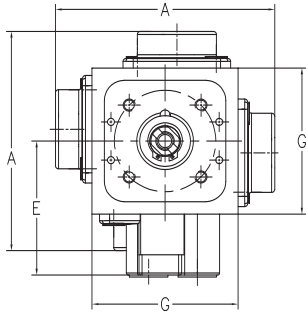

X115

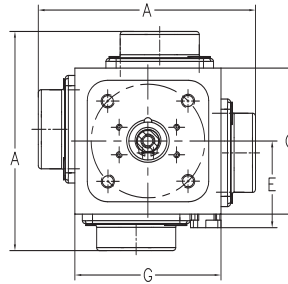

DOUBLE ACTING

X40 - X90

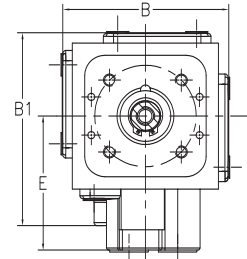

X115

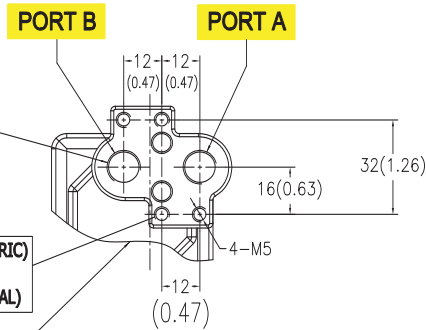
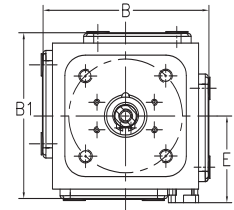

G-1/4" ISO
(FOR METRIC)
1/4" NPT
(FOR IMPERIAL)

M5(FOR METRIC)
10/24 UNC
(FOR IMPERIAL)

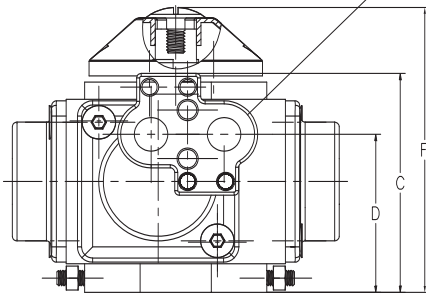

PORT A connected to
the center chambers

PORT B connected to
the outside chambers

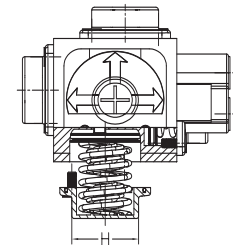
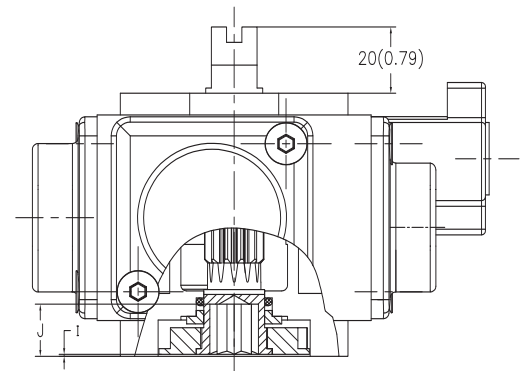

SIZE	A(S/R)		B(D/A)		B1(D/A)		C		D		E		F		G		H		I		J	
	mm	inch	mm	inch	mm	inch	mm	inch	mm	inch	mm	inch	mm	inch	mm	inch	mm	inch	mm	inch	mm	inch
X40	110.0	4.33	84.0	3.31	96.0	3.78	69.1	2.73	51.7	2.04	66.0	2.60	92.5	3.65	72.0	2.84	40.8	1.61	0.5	0.02	14.0	0.56
X50	135.6	5.34	102.6	4.04	117.6	4.63	80.0	3.15	63.4	2.50	77.4	3.05	103.5	4.08	88.0	3.47	50.8	2.00	0.5	0.02	15.5	0.62
X60	164.0	6.46	132.0	5.20	147.0	5.79	98.0	3.86	76.6	3.02	89.5	3.53	120.0	4.73	108.0	4.26	63.5	2.50	0.5	0.02	19.5	0.77
X75	190.0	7.48	152.0	5.99	170.0	6.70	118.0	4.65	93.1	3.67	95.0	3.75	138.5	5.46	126.0	4.97	75.8	2.99	0.5	0.02	22.5	0.89
X90	224.0	8.82	182.0	7.17	202.0	7.96	136.0	5.36	102.5	4.04	114.0	4.49	156.5	6.17	150.0	5.91	91.3	3.60	0.5	0.02	26.5	1.05
X115	274.0	10.79	222.0	8.75	222.0	8.75	165.0	6.50	119.2	4.70	112.0	4.41	189.0	7.45	184.0	7.25	114.4	4.51	0.5	0.02	32.5	1.28

TOP VIEW

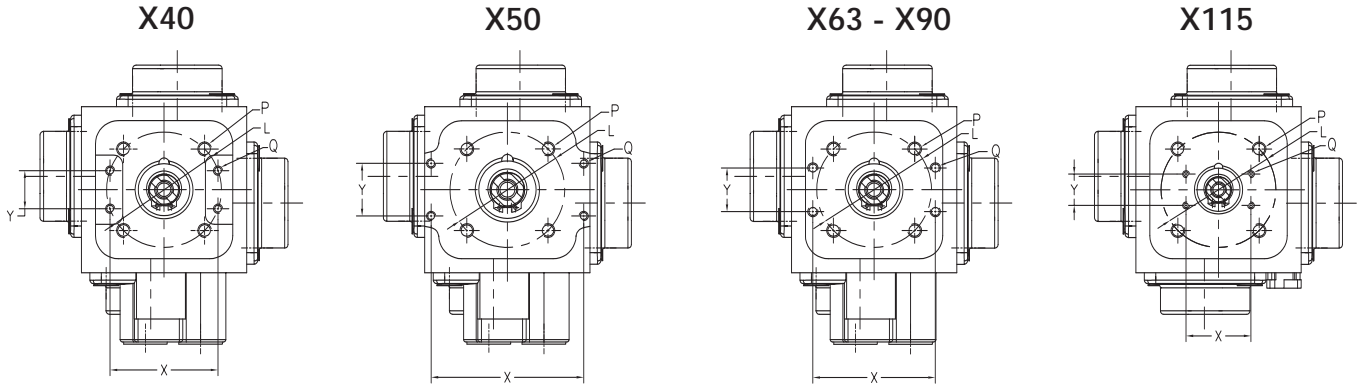

TOP VIEW X40 WITH VDI/VDE BRACKETS (APPLIES ONLY TO X40)

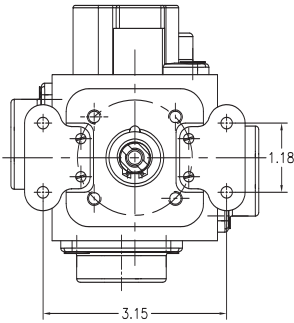

BOTTOM VIEW

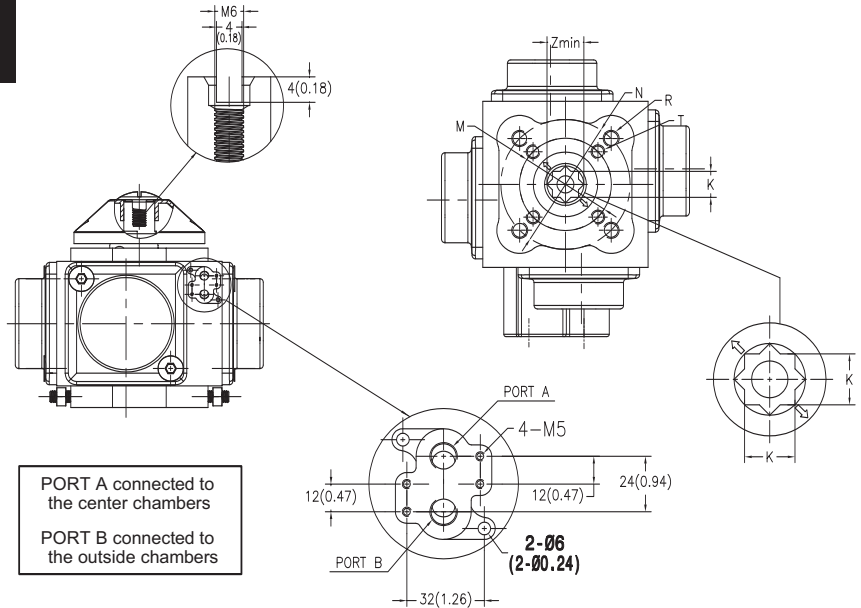

SIZE	K		L		M		N		P		Q		R		T		W		X		Y		Zmin	
	mm	inch	mm	inch	mm	inch	mm	inch	mm	inch	mm	inch	mm	inch	mm	inch	mm	inch	mm	inch	mm	inch	mm	inch
X40	9.0	0.35	50(F5)	1.97(F5)	/	/	50(F5)	1.97(F5)	M6	1/4"	M4	1/16"	M6	1/4"	/	/	40.8	1.61	47.0	1.85	17.0	0.67	12.2	0.48
X50	11.0	0.43	50(F5)	1.97(F5)	50(F5)	1.97(F5)	70(F7)	2.76(F7)	M6	1/4"	M5	1/8"	M8	5/16"	M6	1/4"	50.8	2.00	80.0	3.15	30.0	1.18	14.2	0.56
X60	14.0	0.55	70(F7)	2.76(F7)	70(F7)	2.76(F7)	102(F10)	4.02(F10)	M8	5/16"	M5	1/8"	M10	3/8"	M8	5/16"	63.5	2.50	80.0	3.15	30.0	1.18	18.2	0.72
X75	17.0	0.67	70(F7)	2.76(F7)	70(F7)	2.76(F7)	102(F10)	4.02(F10)	M8	5/16"	M5	1/8"	M10	3/8"	M8	5/16"	75.8	2.98	80.0	3.15	30.0	1.18	22.2	0.87
X90	22.0	0.87	102(F10)	4.02(F10)	/	/	102(F10)	4.02(F10)	M10	3/8"	M5	1/8"	M10	3/8"	/	/	91.3	3.59	80.0	3.15	30.0	1.18	28.2	1.11
X115	27.0	1.06	125(F12)	4.92(F12)	/	/	125(F12)	4.92(F12)	M12	1/2"	M5	1/8"	M12	1/2"	/	/	114.4	4.50	80.0	3.15	30.0	1.18	36.2	1.43

SONIC TORQUE®



HOW TO ORDER

ACTUATOR MODEL	DOUBLE ACTING	SPRING RETURN	DOUBLE ACTING WITH SR. COVER	SPRING CODE	THREAD	OPTIONS
X40 X50 X60 X75 X90 X115	DA	SR	DS	01, 02 03, 04 05, 06 07, 08 09, 10	I = Imperial M = Metric	P1 = High Temp Viton Seals (-4°F to 250°F -20°C to 120°C) P2 = Low Temp EPDM Seals (-40°F to 176°F -40°C to 80°C) P3 = Actuator Locking Device P4 = Reverse Rotation

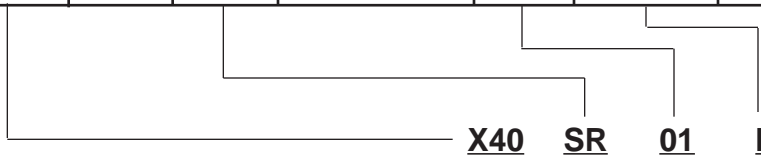

A Division of Smith-Cooper International, LLC

(708) 409-9150

Fax: (708) 409-9151

Email: info@sonictorque.com

www.sonictorque.com

1260 Garnet Drive

Northlake, Illinois 60164 U.S.A.