

SHARPE[®] VALVES



**SERIES 5457
THREADED STANDARD
PORT BALL VALVE**

SERIES 5457

VALVE PARTS AND IDENTIFICATION

ASTM-A216
ASTM-A351
1/4" - 1" 2000 lb. WOG
1-1/4" - 2" 1500 lb. WOG
LOCKING DEVICE
ACTUATOR MOUNTING PAD
STANDARD PORT
BLOWOUT PROOF STEM
STEAM RATINGS: (SATURATED)
WITH REINFORCED TEFLON
SEATS 150 WSP
WITH NOVA SEATS 250 WSP

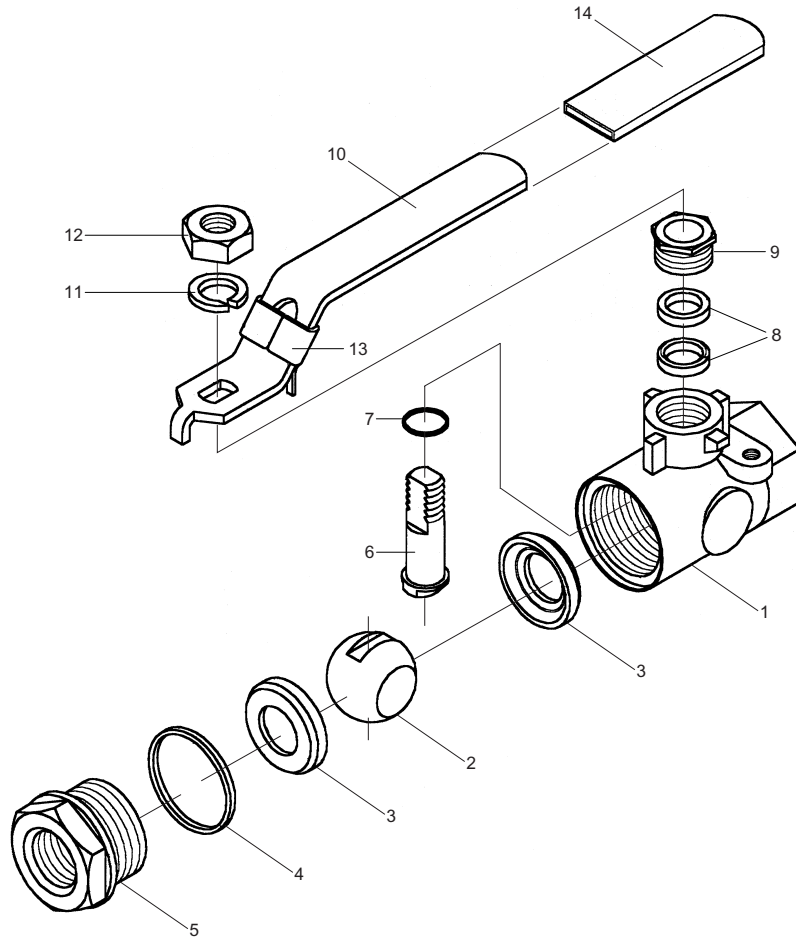

PART NO.	PART	QTY.	MATERIAL
1	Body	1	ASTM-A216 WCB ASTM-A351 CF8M
2	Ball	1	316 Stainless Steel
3	Seat	2	RPTFE / NOVA
4	Body Seal	1	PTFE / Graphite
5	End Plug	1	ASTM-A216 WCB ASTM-A351 CF8M
6	Stem	1	316 Stainless Steel
7	Thrust Washer	1	PTFE
8	Stem Packing	2	PTFE / Graphoil
9	Packing Nut	1	Stainless Steel - 316
10	Handle	1	Stainless Steel - 304
11	Lock Washer	1	Stainless Steel - 304
12	Handle Nut	1	Stainless Steel - 304
13	Locking Device	1	Stainless Steel - 304
14	Handle Sleeve	1	Plastic

SERIES 5457 VALVE DIMENSIONS

1/4" - 1"

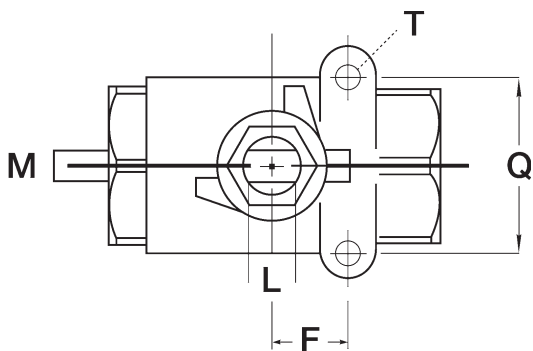

1-1/4" - 2"

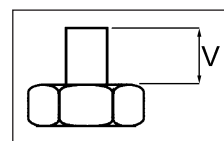
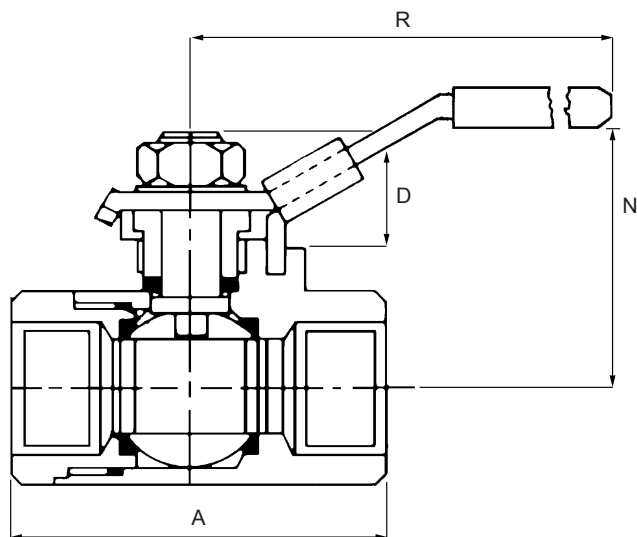
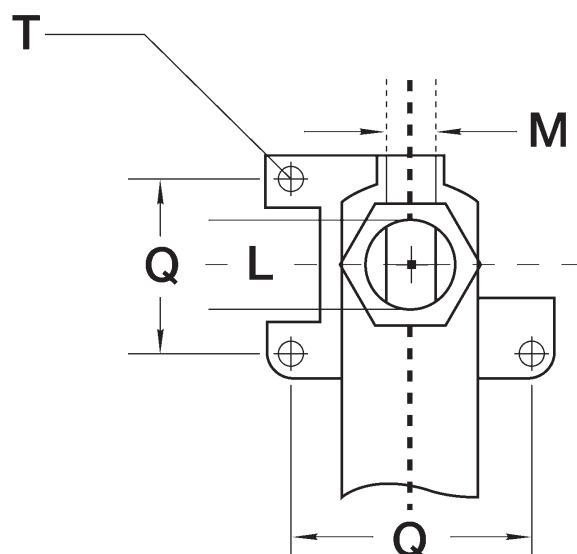

1/4" - 2"
STEM ARRANGEMENT
FOR SERIES 5457

SIZE	A	D	N	R	Q	F	M	L	T	V	PORT SIZE	APPROX. WEIGHT
1/4"	2.25	0.95	1.75	4.00	1.10	0.45	0.22	0.30	10 - 24	0.30	0.50	0.60
3/8"	2.25	0.95	1.75	4.00	1.10	0.45	0.22	0.30	10 - 24	0.30	0.50	0.60
1/2"	2.32	1.12	2.00	4.00	1.10	0.45	0.22	0.30	10 - 24	0.32	0.50	0.55
3/4"	3.12	1.20	2.20	5.00	1.35	0.85	0.25	0.42	10 - 24	0.35	0.70	1.10
1"	3.37	1.20	2.45	5.00	1.35	0.85	0.25	0.42	10 - 24	0.35	0.88	1.50
1-1/4"	4.10	1.06	3.40	5.75	1.40*	---	0.37	0.61	1/4 - 20	0.50	1.00	2.75
1-1/2"	4.35	1.10	3.40	5.75	1.40*	---	0.37	0.61	1/4 - 20	0.50	1.25	3.50
2"	5.40	1.10	3.75	5.75	1.40*	---	0.37	0.61	1/4 - 20	0.50	1.50	5.25

CV* DATA

1/4"	6
3/8"	6
1/2"	9
3/4"	24
1"	35
1-1/4"	47
1-1/2"	81
2"	105

*CV: The volume of water in gal./min. that will pass through a given valve with a pressure drop of 1 PSI.

SHARPE® VALVES

Pressure/Temperature Ratings - Sharpe® Series 5457 Non-welded Configuration

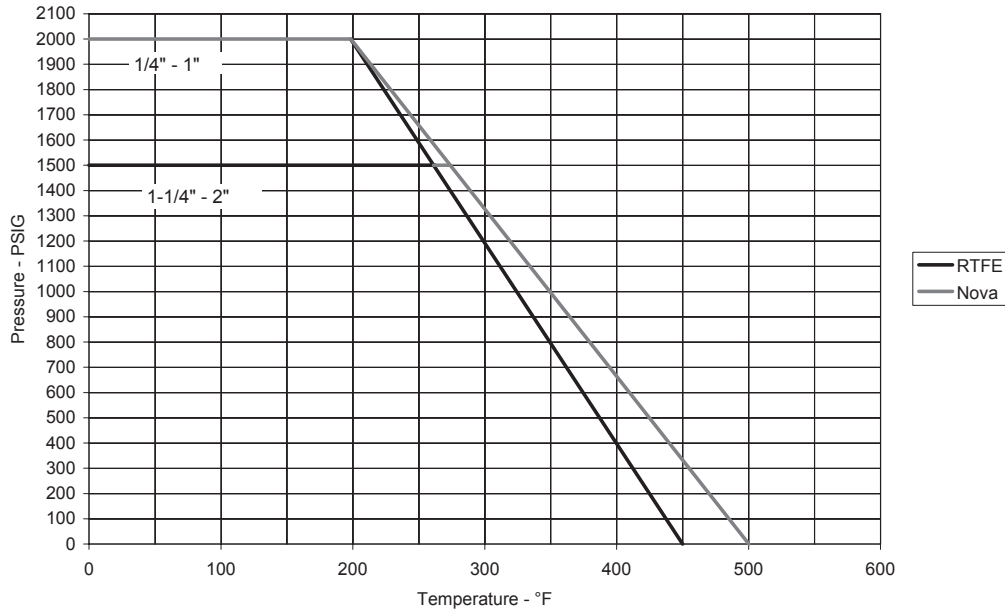

HOW TO ORDER

VALVE SIZE	VALVE SERIES	BODY & ENDS	SEAT & SEAL
1/4" 3/8" 1/2" 3/4" 1" 1-1/4" 1-1/2" 2"	5457	4 = Carbon Steel 6 = Stainless Steel	RT Seats PTFE Seals as Standard N = Nova Seats/ Graphoil Seal

3/4" 5457 4 N

SHARPE® VALVES

A Division of Smith-Cooper International, LLC

Toll-Free 1-877-7SHARPE

(877) 774-2773

Fax: (708) 562-9250

E-Mail: info@sharpevalves.com

www.sharpevalves.com

1260 Garnet Drive

Northlake, Illinois 60164 U.S.A.